



CLASS

TILE BRIDGE SAWS

CONTROL BOARD

The control board includes:

- Switch with release coil.
- Overheat protection with manual reset in the event of the disk jamming.
- Red light for net connection.
- Green light for machine on function.
- Laser instrument for the maximum cutting precision.

EXTENSION SIDE BENCH

It is very practical when need to cut large size of tiles and marble slabs.

OPTIONAL

STORAGE

Built to reduce at the minimum the encumbrance during the carriage and above all the storage space.

	Art. 65671	Art. 65670	Art. 65901	Art. 65900
DIAMOND DISK (special gres included)	ø200 mm. (int ø25,4 mm.)	ø200 mm. (int ø25,4 mm.)	ø200 mm. (int ø25,4 mm.)	ø200 mm. (int ø25,4 mm.)
ENGINE	230V 50Hz 1000W	230V 50Hz 1000W	230V 50Hz 1000W	230V 50Hz 1000W
ROTATION SPEED	2800 rpm.	2800 rpm.	2800 rpm.	2800 rpm.
MAX CUTTING LENGTH	670 mm.	670 mm.	900 mm.	900 mm.
MAX CUTTING DEPTH	40 mm.	40 mm.	40 mm.	40 mm.
MAX CUTTING DEPTH AT 45°	40 mm.	40 mm.	40 mm.	40 mm.
MAX SIZE TILE FOR DIAGONAL CUT	450 x 450 mm.	450 x 450 mm.	620 x 620 mm.	620 x 620 mm.
WORKING TABLE SIZE	524 x 650 mm.	524 x 650 mm.	520 x 437 mm.	520 x 437 mm.
WATER RECYCLING PUMP TYPE	S0 Type	S0 Type	S0 Type	S0 Type
KIT WHEELS	Standard	Optional	Standard	Optional
LASER INSTRUMENT	Standard	-	Standard	-
DIMENSION MACHINE IN SERVICE	660x1070x h. 1200 mm.	660x1070x h. 1200 mm.	660x1300x h. 1200 mm.	660x1300x h. 1200 mm.
DIMENSION MACHINE IN STOCK	720x1100x h. 940 mm.	720x1100x h. 940 mm.	720x1300x h. 940 mm.	720x1300x h. 940 mm.
DIMENSION 3 MACHINES ON PALLET	720x1100x h. 2260 mm.	720x1100x h. 2260 mm.	720x1300x h. 2260 mm.	720x1300x h. 2260 mm.
NET WEIGHT	40 Kg.	37 Kg.	44 Kg.	41 Kg.



*Designed
and made
in Italy*



BATTIPAVTM
MACCHINE PER EDILIZIA | MACHINES FOR BUILDING

AUTHORIZED DEALER:



Z. i. 2 - Via Cavatorta, 6/1 | 48010 Cotignola (Ra) | ITALY
Tel. +39 0545 40004 | Fax +39 0545 41724
www.battipav.com | sales@battipav.com

July 2012

APPLICATION

Built to cut stoneware, porcelain, tiles and marble.

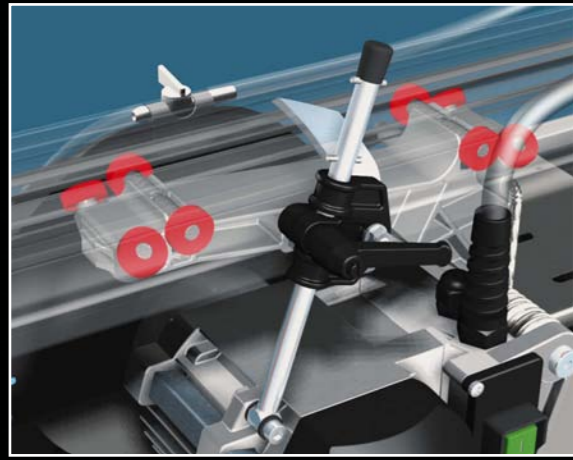

The carriage engine group slides with 8 ball-bearings on interchangeable stainless steel track. So doing the sliding is very fast and precise.



TILE SUPPORT
Very precise tile support with millimetric scale of quick reading.



Position 45° angle cuts.



The cutting head is horizontally pivoted and can be locked at the intended height. It makes every kind of shape.



ORIGINAL RECYCLING PUMP

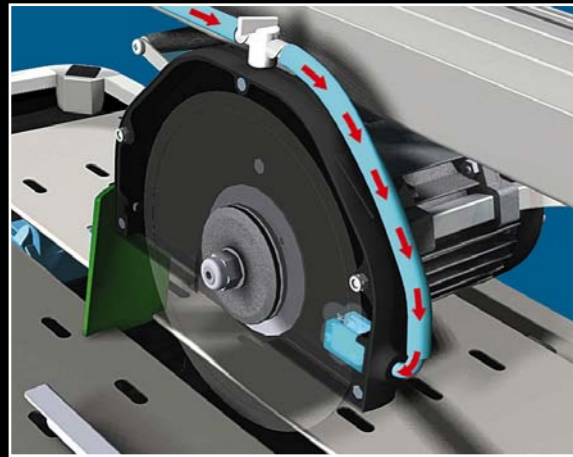

Spray system

DISK'S LUBRICATION

wdec
WATER DECANTING SYSTEM

FastLEG
LEG FASTENING SYSTEM

